

39' ELEMENT TRUSS KIT for the 4 Element

Item	QTY	Part #	Description
	2	10-1601-21	2" Solid Aluminum Saddle
	4	60-0107	3/16" X 2" welded SS eye bolt
	2	60-0083	4" SS Turnbuckle
	2	60-0106	3/4" SS ring
	1	60-0110	1/4" x 1 1/4" SS hex bolt
	1	60-0030	1/4" SS nylock nut
	2	60-0065	5/16" X 3 1/2" SS hex bolt
	2	60-0046	5/16" SS nylock nut
	2	60-0033	5/16" SS washer
	4	60-0111	10-24 SS nylock nut
	2	10-1055-01	60" Dacron rope with 2 crimped loops
	2	10-1055-11	202" Dacron rope with 1 crimped loop
	1	10-1029-01	Connector protector
	1	09-0001	PVC electrical tape
	1	10-1054-01	38" Aluminum truss support
	1	60-0112	1/4" X 10-32 SS set screw

Truss Option Assembly Procedure

1. Check and inventory that you received all the parts for your new 30m/40m truss option kit

2. Apply connector protector to the threads of the 5/16" X 3-1/2" hex bolt ONLY.
DO NOT APPLY connector protector to any plastic part on your antenna.

3. It is critical that you mount the truss support on the opposite side of the mast plate. This will prevent the truss rope from rubbing on the boom truss. Use the boom to eye-ball the truss support so that it is perpendicular to the elements. This is also not critical as long as you get it as close vertical as possible.

4. Secure the truss support to the aluminum saddles so that the head of the 5/16" bolts are on the truss support side. (**Figure 2**) Secure the truss support and saddle assembly around the boom so that its between the driven EST and return EST (**Figure 1**) To obtain extra holding force use the 10-32 set screw (60-0112) and screw it into the tapped hole on your saddle.

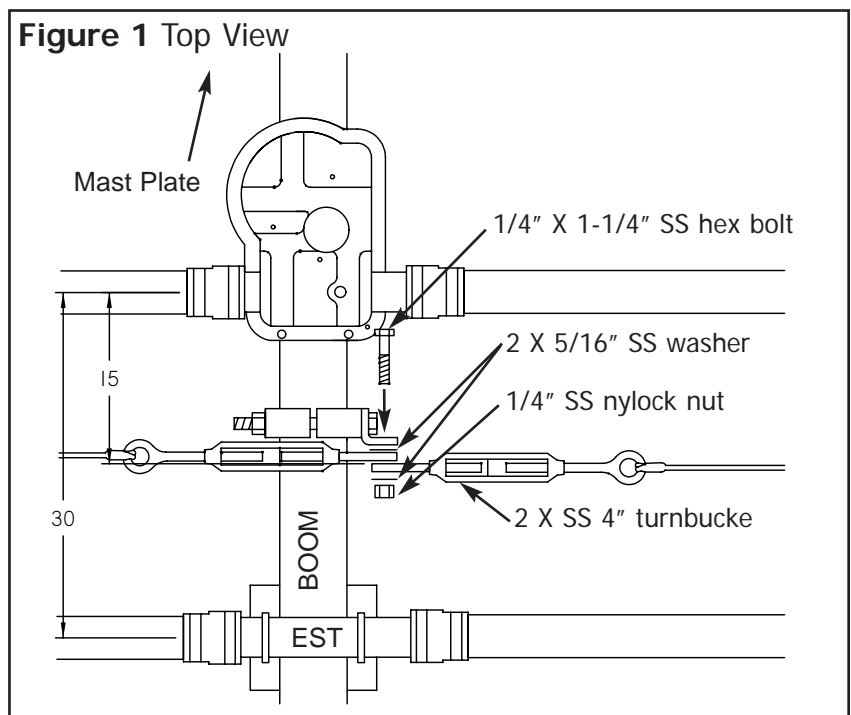

5. Follow the assembly in **(Figure 1)** to mount the turnbuckles on the truss support. Do not attach the rope at this time.

6. If you are receiving your truss support with your new antenna, skip the following step. If you are adding your truss support option to your existing antenna you will have to drill out four 3/16" holes on the couplers that are mounted in the sweeps of the 30m/40m dipole. **(Figure 3 Top View)** For drilling procedures.

7. Locate the small section of Dacron rope (10-1055-01), it will have two loops on each end. Secure each 3/16" SS eye bolt to the loops of the small Dacron rope by threading the loop of the rope through the eye of the eye bolt. Pull the loop over the shank of the eye bolt and then tighten the rope by pulling the opposite end of the Dacron rope. Repeat this procedure for the other eye bolt.

8. Unscrew the SS nut from the eye bolt and discard. It is used for other SteppIR applications. You will use the small SS washers so be sure to keep for this assembly. Secure the eye bolt to the coupler on your 30m/40m sweep. **(Figure 3 Assembly View)**

9. Secure 3/4" SS ring to the small section of the Dacron rope. Use the same procedure that was used to attach the eye bolts to the rope, but position the SS ring in the middle of the small Dacron rope. Think of the SS ring as the eye bolt without the shank for securing it to the small section of rope. **(Figure 4)**

10. Locate the long section of Dacron rope, secure the looped end of the rope to the SS ring. Thread the loop of the long rope through the 3/4" SS ring and pull the unlooped side of the rope through the looped end and pull the excess to secure the long rope to the SS ring. See **(Figure 4)** for SS ring assembly.

Figure 2 Side View

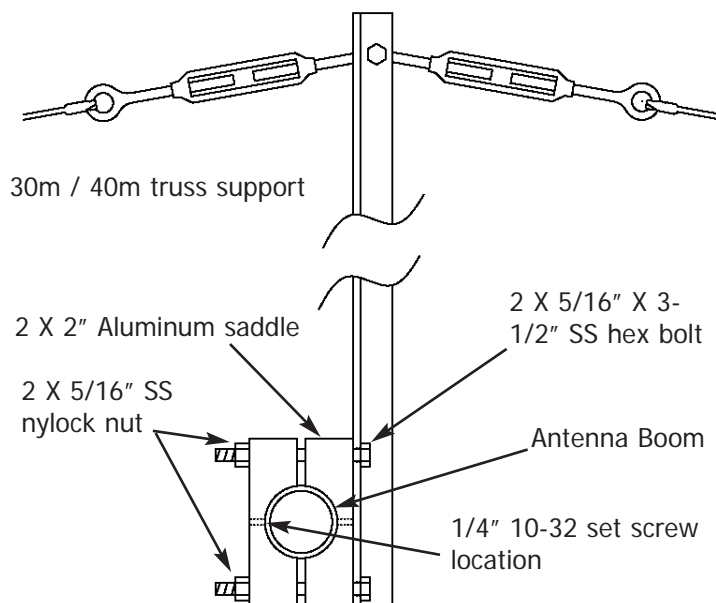

Figure 3 Coupler Assembly

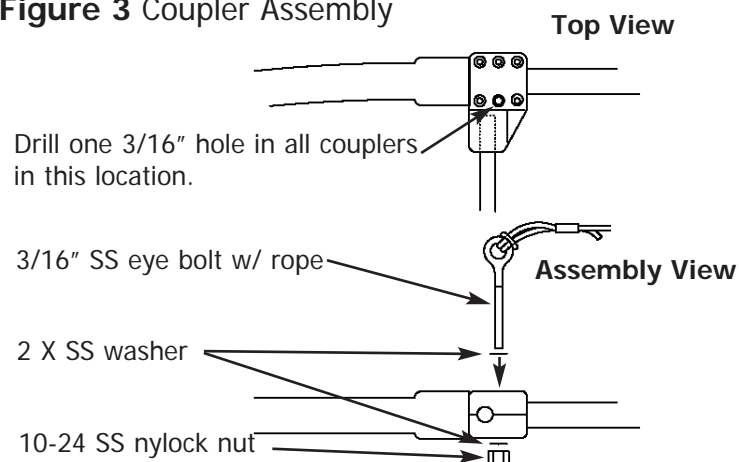
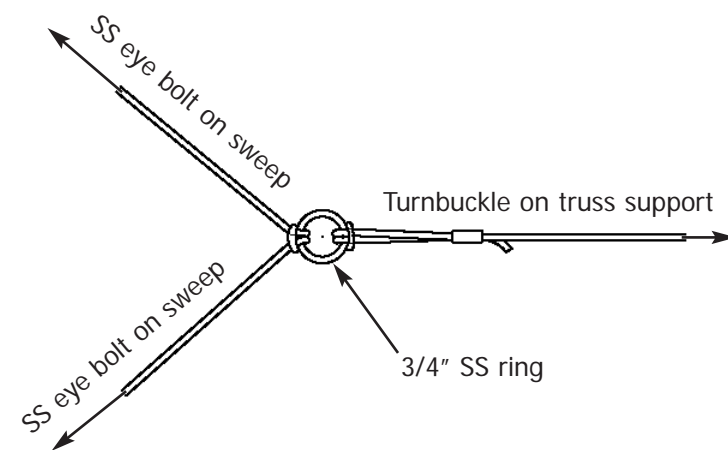

Figure 4 SS ring Assembly



11. Lengthen the turnbuckles as long as possible without them coming apart. To attach the loose end of the long Dacron rope you will need to run the rope through the open eye of the turnbuckle. Pull the rope tight enough so that the telescoping poles are close to level. It is easier if you have someone help to lift the tip of the loop while you secure the truss rope. Once the dipole loop is close to level secure the rope to the turnbuckle by looping the rope twice through the eye and tying 3 half hitches. Finish the knot by covering the half hitches with the provided electrical tape.

12. Use the turnbuckles to do any fine tune adjusting to your element. DO NOT pull up too high on your dipole truss. This will cause the element to collect water and damage your antenna. Do not allow your telescoping poles to make an "S" shape if looking from the truss support to the sweep. It should be a gradual curve down, but the tip of the sweep should never be higher than any other part of the telescoping pole.

13. Repeat steps 6-12 to complete the other half of the truss support.

14. Some small adjustments may be needed with both sides of the truss support assembled. This can be done by shortening or lengthening the turnbuckles. Once both sides are adjusted, lock down the turnbuckle by tightening the small nuts onto the housing of the turnbuckle.

15. You should have enough extra rope at the turnbuckle to tie lock the turnbuckles. This can be done by threading the loose end of rope through the turnbuckle housing, between the eye bolt shanks. Then through the opposite eye that is attached to the truss support. Weave the loose end back through the turnbuckle housing and terminate at the lower eye of the turnbuckle, using two half hitches.

16. To finish the assembly, use the provided electrical tape to tape around the half hitches.

