



Addendum Manual

IMPORTANT:

Please be certain to read this manual before you install your antenna - check for any changes in installation procedures that have not yet been implemented into the installation manual.

REV 3 (April 2012)

TABLE OF CONTENTS

Antenna	Page(s)
2E Yagi (see below if you have 40/30 loop option)	1, 2-3, 4, 10
3E Yagi (see below if you have 40/30 loop option)	1, 2-3, 4, 10
4E Yagi (see below if you have 40/30 loop option)	1, 2-3, 4, 10
DB11 Yagi	4
DB18 / DB18E Yagi	1, 2-3, 4-8, 10, 13, 14
DB36 Yagi	1, 2-3, 4-8, 10, 11, 12, 13
DB42 Yagi	1, 2-3, 4-8, 10, 11, 13
BigIR Vertical	1, 2-3, 4-8, 9
SmallIR Vertical	1, 2-3, 4
20m-6m Dipole	1, 2-3, 4
40m-6m Dipole	1, 2-3, 4-8
Any antenna with 40/30 loop (except DB11)	1, 4-8, 13
40/30 loop upgrade	1, 4-8, 13
All Antenna models	15

EHU ASSEMBLY - ALL ANTENNA MODELS

Follow the directions below for wiring each of your element housing units (EHU) from the respective EHU to either the terminal housing, or the connector junction box, if you have purchased this option.

NOTE:

- Follow **figure 1** for wiring and routing cable in the wire tray on the lip of the EHU.
- Depending on EHU type there will be 4 conductor or 6 conductor wire. Follow the wiring code that is printed on the circuit board inside the EHU as shown in **note A**.
- Be sure to unplug the top portion of the connector when wiring, as you cannot see the correct wiring code until the upper plug is removed. The correct wiring code is printed closest to the terminal block and reads left to right: **Bk, R, G, W, Blu, Br**. For 4 wires use **Bk, R, G, W** and ignore Blu & Br. For 6 wires use: **Bk, R, G, W, Blu, Br**.
- Trim the shield wire so that it is not exposed inside the EHU.

Figure 1

Wiring EHU

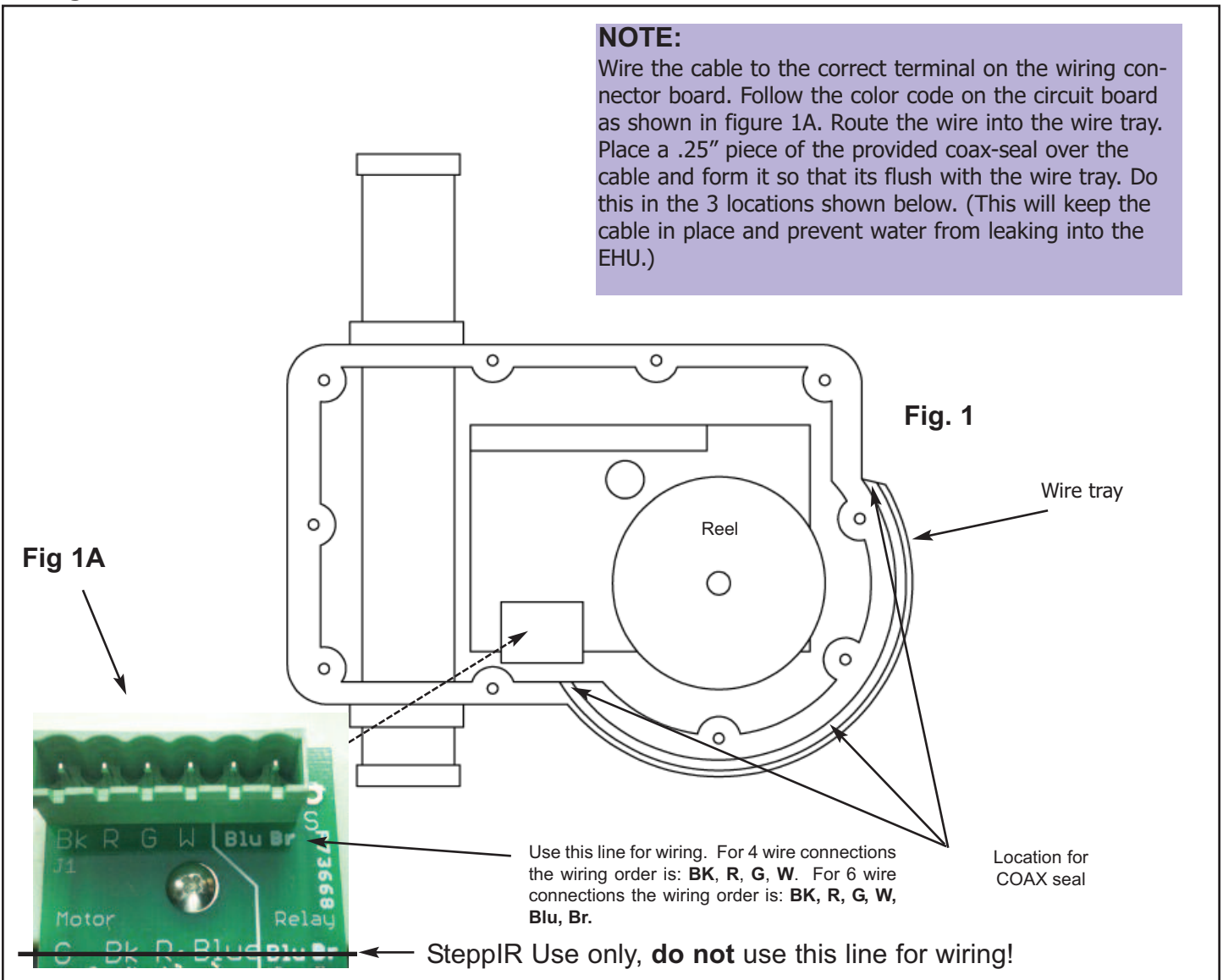

DB25 SPLICE ASSEMBLY INSTRUCTIONS - ALL ANTENNA MODELS

These instructions are for all customers that have purchased the cable splice option for connecting the control cable to the SDA 100 controller

INSTALLING THE OPTIONAL DB25 CONTROL CABLE SPLICE (70-6010-01) (FOR CONNECTING CONTROL CABLE TO THE SDA 100 CONTROLLER)



Figure 1

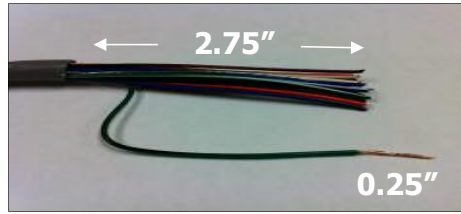

Figure 2

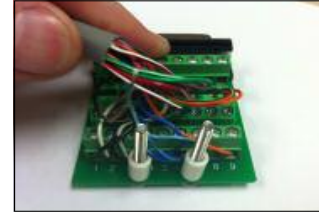

Figure 3



Figure 4



Figure 5



Figure 6



Figure 7

The DB25 control cable splice allows for much more convenient connection of control cable to the SteppIR controller. By utilizing this connector splice, there is no need to cut the DB25 connector off and re-solder when running cable through conduit. In addition, now you can purchase custom cable lengths to within 1 foot of your desired length, eliminating potential for excess cable. To install the DB25 control cable splice, follow these instructions:

1. Locate the parts needed for installation shown in figure 1.
2. Strip the grey jacket and aluminum shielding off of the control cable as shown in figure 2, approximately 2.75" from end of control cable, being careful not to damage the individual wires. Strip the plastic insulation off of each of the control cable wires, approximately 0.25" in length should be bare wire. It helps to twist each of the stranded wires, to aid in the placing of the wire into the terminal headers. Tinning the wires also works well.
3. Connect each wire to the appropriate terminal as shown in figure 3. Consult the drawing on the next page for the correct wiring sequence, there are multiple wiring sequences on this drawing depending on your model of antenna.
4. Insert the two stainless steel screws into the circuit board, as shown in figure 3. Slide the two plastic spacers onto the screws.
5. Insert the first half of the strain relief clamp onto the two screws (half-round cutout facing upward) on the two screws (fig 4). Be careful not to pull the wires out of the terminal headers as you push the strain relief clamp downward.
6. Insert the second half of the strain relief clamp onto the two screws (half-round cutout facing downward, fig 3).
7. Position the control cable in between the two halves of the strain relief clamp, be sure that the jacketing of the cable is in between the clamps as shown in figure 5.
8. Using the nuts, tighten down until the cable is nice and snug, but do not over tighten (fig 5).
9. Plug the DB25 splice into the back of the controller and tighten the jack screws to secure the DB25 to the controller housing, as shown in figure 6.
10. While it is not required, you may optionally use silicone wrap to cover the wiring, as shown in figure 7.

DB25 SPLICE ASSEMBLY INSTRUCTIONS CONTINUED

This is the wiring diagram for each respective antenna.

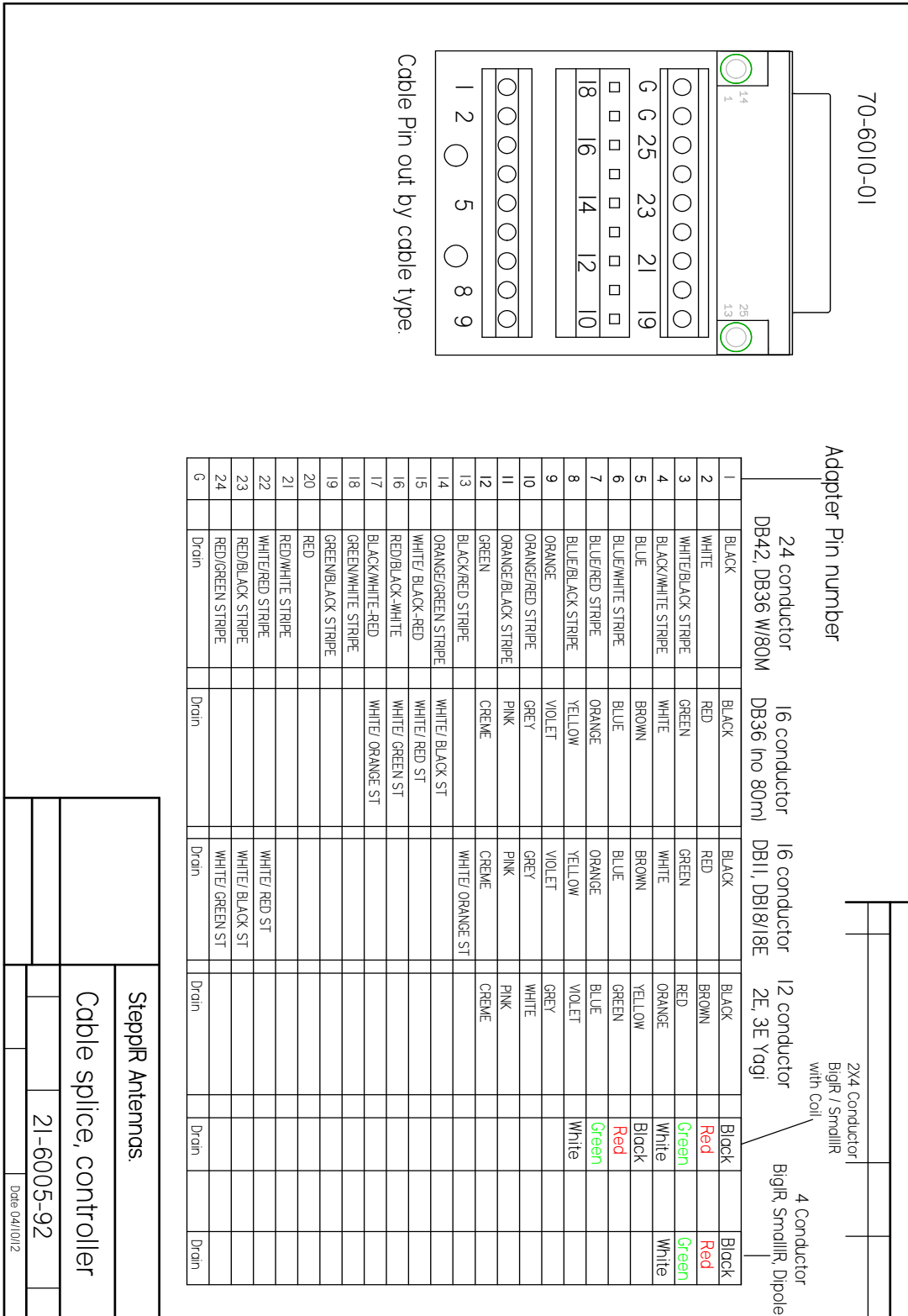

Preparing the telescoping pole tips for the 40/30 loop elements

- Extend the telescoping poles to full length by firmly “locking” each section of the pole in place. A good methodology is to position each half of the joint so that they are several inches apart (while still within each other), and then pull quickly and firmly. Do this for each pole.
- With poles fully extended, trim the end of the tip element of each pole so that the pole is 212.75 inches (540.4 cm) from the tip of the pole to the butt end, as shown in **figure 1.01**. You need to trim ONLY the poles used for the 40/30 loops—if your antenna has 20m-6m straight elements, those do not need trimming. Use a hack saw or similar cutting blade that is suitable for fiberglass.
- Using the included conical drill bit, chamfer the ends of the 40/30 poles as shown in **figure 1.02**. **Figure 1.03** shows the proper angle to chamfer to. Be sure to clean out the interior of the fiberglass poles before continuing. Debris inside the telescoping poles can lead to failure of the EHU.

Secure polyolefin heat shrink to the telescoping pole joints

- On all the telescoping fiberglass elements we now include double wall polyolefin heat shrink, part number #03630. Each telescoping pole uses 3 of the polyolefin heat shrink pieces, so on a 20m-6m element half, 3 pieces are used and on a 40/30 element half, six pieces are used. Once finished, the seal is secure and waterproof. This product requires a heat gun for activation of the adhesive.
- When positioning the heat shrink, place it so that the joint of the telescoping pole is centered in the middle of the heat shrink. **Figure 1.04** below shows how this is done.
- Using a heat gun (hair dryers will NOT work), apply heat evenly around the entire area of heat shrink. Note: There are 4 blue colored lines imprinted on the tubing. The joint is considered done being heated and waterproof when the lines change color to a yellowish green. Each line needs to change in color to ensure even adhesion temperatures.

Figure 1.01



Figure 1.02

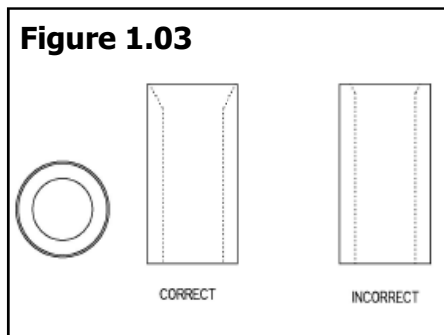

Figure 1.03



Figure 1.04

40/30 Loop Antennas (continued)

Preparing the pole tips for insertion into the loops

- Prepare each of the 40/30 telescoping poles as shown in **figure 1.05** for insertion into the plastic loops. The telescoping poles for the non-loop elements do not require this preparation.
- Secure 10 wraps of electrical tape 0.70 inches from the tip, as shown in figure **1.05, Step 2**. This is used as a measuring stop to be certain you insert the pole in the proper depth. It is important to NEATLY wrap the electrical tape so it has a clean edge.
- Cut a 4 inch piece of blue silicone wrap (PN off of the included roll). **Wrap the silicone tape around the pole in a clockwise direction – this is very important.** Try to make the silicone tape wrap so that it is flush with the electrical tape as shown in figure **1.05, Step 3**. Firmly pull the silicone tape as you go around the pole. The silicone tape will stick only to itself. This tape is used to form the seal between the pole tip and the plastic sweep tube. The silicone tape will deform as you pull it, to about half it's original width—try to keep the edges as even as possible while you wrap it onto the pole tip.
- Wrap the included 3M grip tape (PN 09-0013) around the pole, flush with the edge as shown in **figure 1.05, Step 4**. Be sure there is no overlap of the grip tape – it should be fine from the factory but the OD of poles varies slightly, so if there is overlap, make sure you trim the tape so there is a gap, as shown in **figure 1.05, Step 4**.

Figure 1.05

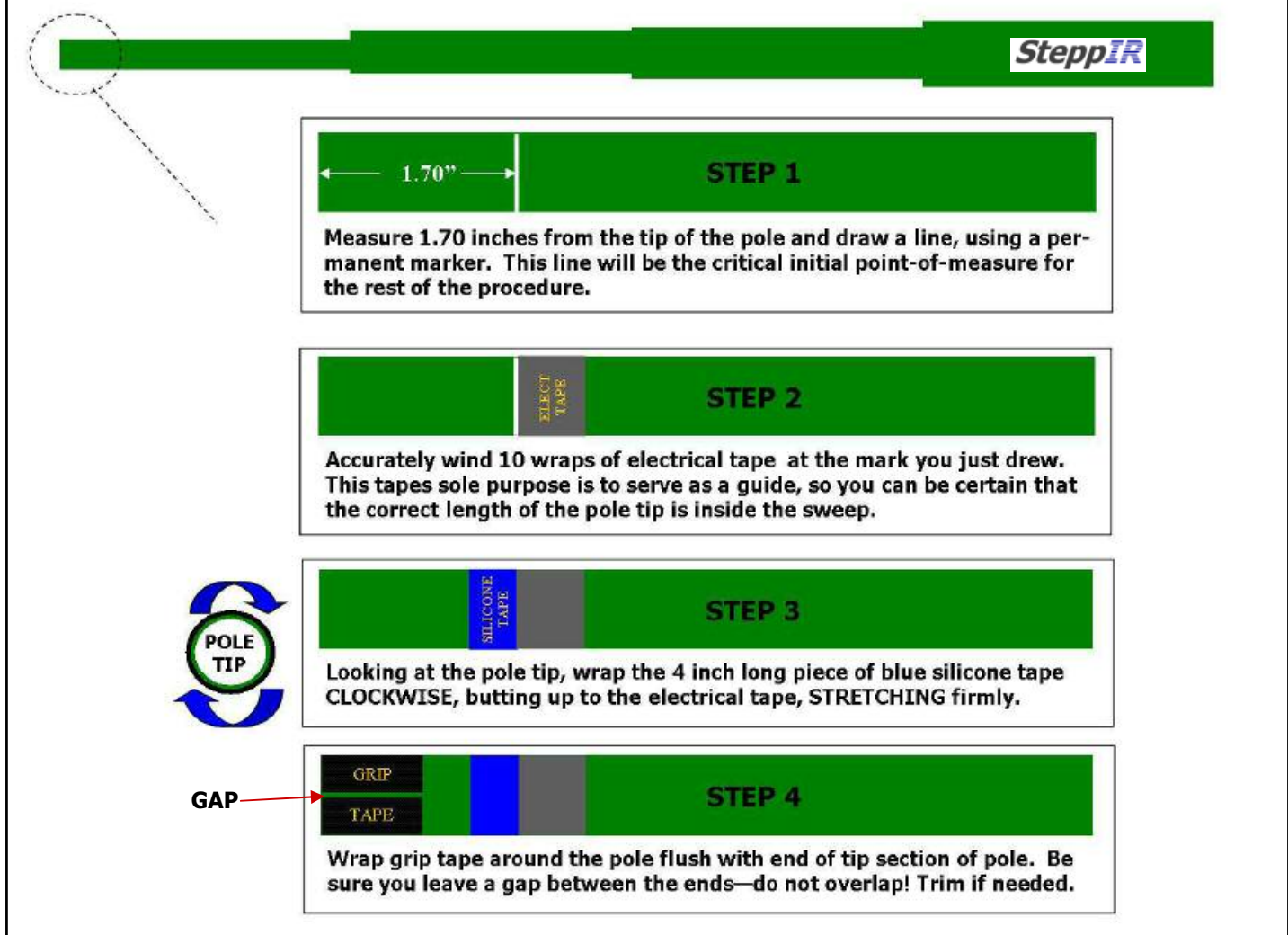

NEW Plastic Sweep Installation Instructions 40/30 Loop Antennas (continued)

Attach the sweep couplers to the plastic sweep tubes

- Each of the sweep coupler halves (PN 10-1155-01) will have a notch in the mold on one side. **It is critical that these notches are pointing towards the sweeps or they will not work properly.** See **figure 1.06** for the location of the mark. Be certain that each half of the coupler has the mark facing the sweep tube!
- Place the coupler halves on the end of the plastic sweep tubing as shown in **figure 1.07** . Insert the four 60-0156 #6 x 2" screws. Place the screws so that the threaded portion of the screw is facing downward. **BE SURE THAT THE DRAIN HOLES FOR THE PLASTIC SWEEP TUBE ARE POINTING DOWNWARD BEFORE INSTALLING THE COUPLERS.** Apply anti-seize to the threads and place the nylock nuts on. Tighten nuts until there is approximately a 0.25" gap between the two coupler halves as shown in **figure 1.08**. Repeat for other side of sweep tube.
- The couplers are designed to re-form the plastic sweep to lock them in place. Do not be alarmed if there is a need to exert a fair amount of force when tightening the screws—this is necessary in order to re-form the plastic sweep tubing.
- These screws will be completely tightened later, tightening to this point provides a framework for the ensuing steps.

Figure 1.06

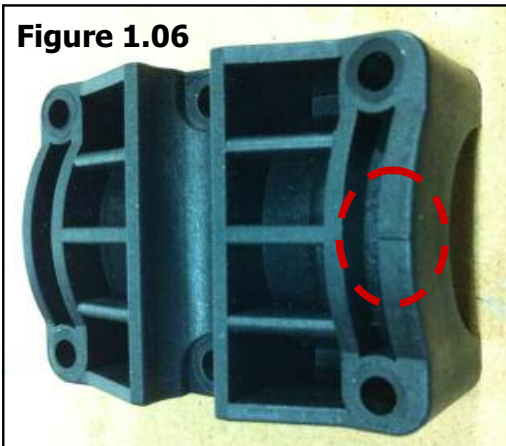

Figure 1.07

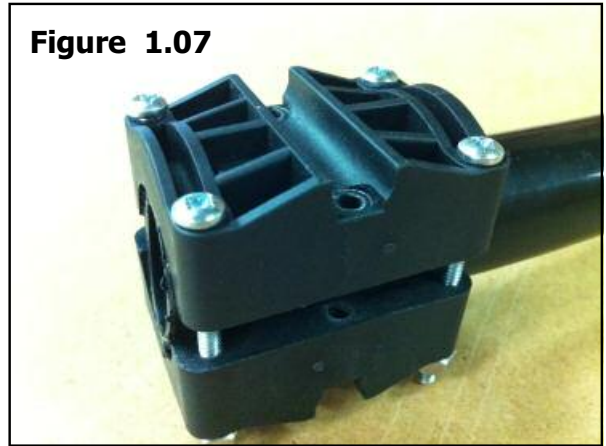

Figure 1.08



NEW Plastic Sweep Installation Instructions 40/30 Loop Antennas (continued)

Mounting the fiberglass spreaders

- Mount the black fiberglass sweep spreaders (PN 10-1503-21) to the sweep couplers. There is a concave mounting area on each side of the plastic couplers. Position the fiberglass spreader so that the holes align with the clam shell couplers as shown in **figure 1.09**. When installing the fiberglass spreader, you will want the spreader to be underneath the plastic coupler as shown in **figure 1.10**. The spreaders will be longer than the couplers on each side of the loop. This is done on purpose to ensure plenty of fiberglass material is on each side of the screw.
- Insert #6 x 2" pan-head screw (PN 60-0156) through each of the coupler halves and the fiberglass rod. This screw must be placed so that the Nylock nut (PN 60-0014) is resting on the top of the fiberglass material and the Phillips end of the screw is resting inside the concave groove. **Refer to figures 1.09 and 1.11** for detail. The screws are longer than normal so that you can get the nut on in the initial stages.
- Tighten the Nylock nuts firmly. Be sure to use anti-seize on these screws or they very likely will gall and have to be replaced.
- Repeat for each side of the plastic sweep.



40/30 Loop Antennas (continued)

Connecting the telescoping poles to the plastic sweeps

- Insert the pole tip into the plastic coupler. If for some reason you cannot get the pole into the plastic sweep, it is probably because the plastic sweep material is too elongated still. This may seem counter-intuitive, but tighten the plastic sweep couplers until the shape at the end becomes more cylindrical as shown in **figure 1.12**.
- As you push the tip inward, turn the pole clockwise in a corkscrew manner as shown in **figure 1.13**, so that the tape does not unwind or kink during the process. Push the pole until it butts up against the plastic coupler as shown in **figure 1.14**. A small amount of the blue silicone tape will protrude out of the coupler joint.
- Finish tightening the four screws on the outside corners of the plastic coupler. Tighten evenly, in an automobile X type pattern as shown in **figure 1.15**. If you do not tighten evenly, you may break the fastener. Once the outsides are firmly tight, tighten the two screws that hold the fiberglass spreader in place. **Figure 1.16** shows a suggested method for tightening the screws.
- When completely tightened, the sweep couplers should have just a slight gap, as shown in **figure 1.17**.
- **Figure 1.18** shows the completed sweep—repeat process for each sweep.

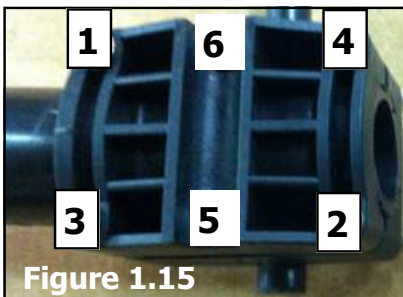
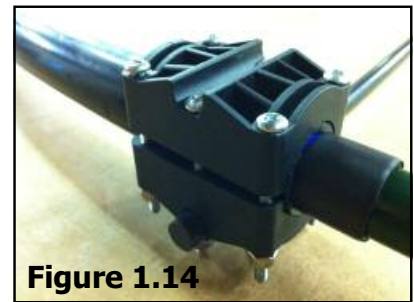
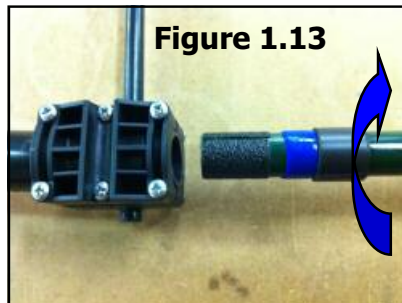

BigIR EST Installation

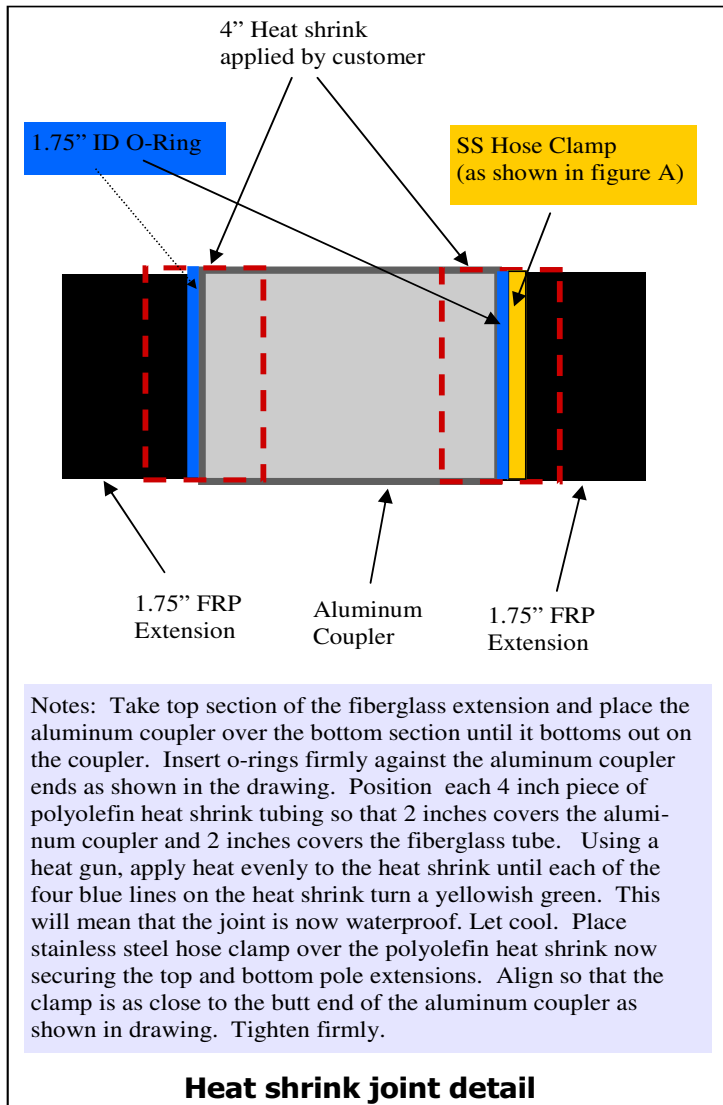
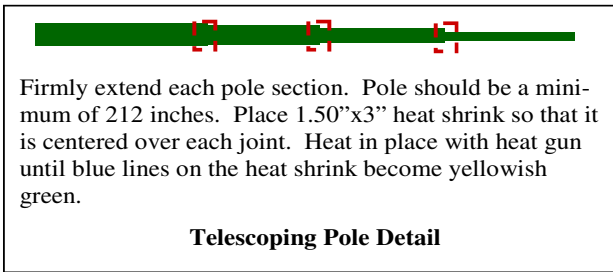

72-1003 Parts List:

- Qty 3: #03631 2.05" x 4" polyolefin heat shrink
- Qty 3: #03630 1.50" x 3" polyolefin heat shrink
- Qty 1: #60-6000-20 2.0" SS Hose clamp
- Qty 3: #10-1104-11 1.75" OD O-ring

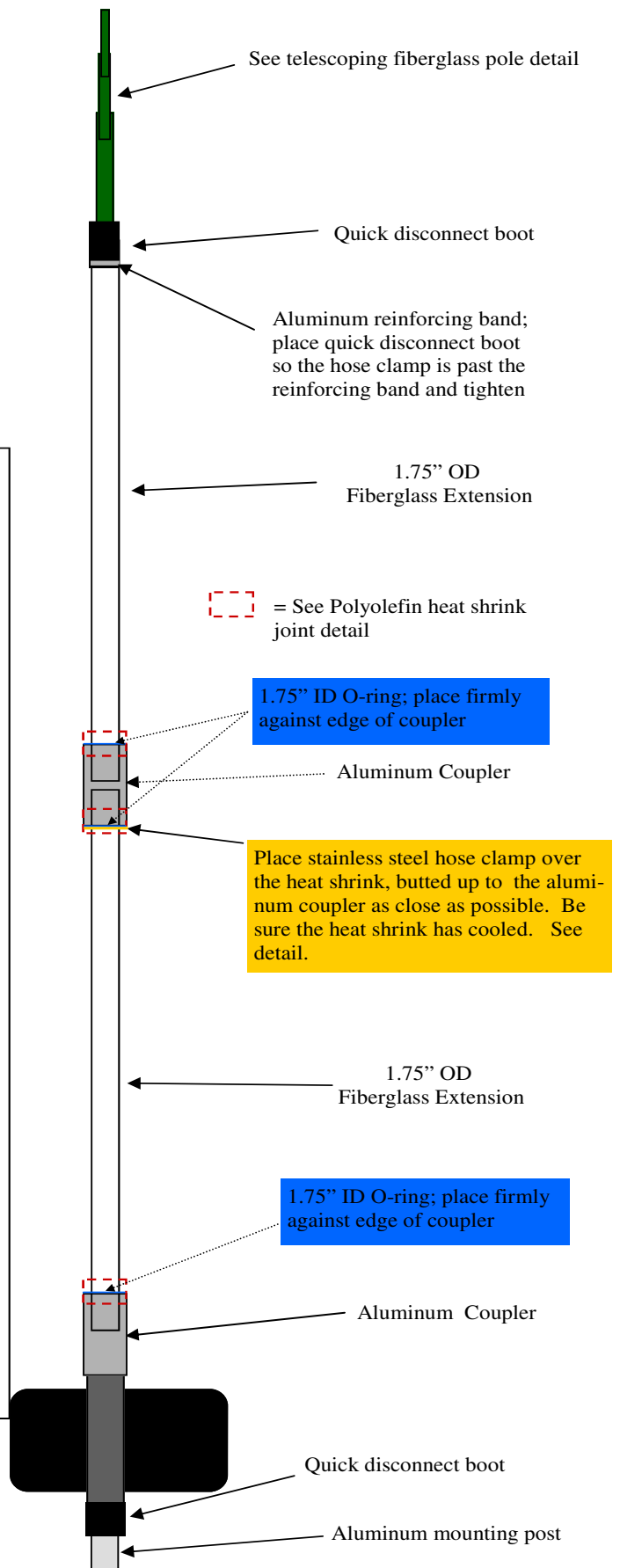

Foam Plug Assembly - All non loop antennas

70-1007-01 FOAM PLUG ASSEMBLY

Each 20m-6m element tip requires a breathable foam plug to be inserted onto the tip end of it so that the element is allowed to vent, but not let any non-liquid enter into the antenna. The foam plug assembly is NOT required for 40/30 elements.

The foam plug assembly consists of the foam plug, and a flexible plastic housing for it as shown in Figure 1. The foam plug is sent to you already inside the black flexible housing.

1. Insert the gray foam plug into the black flexible plastic housing. Push the foam plug into the plastic housing until it bottoms out as shown in Figure 2.
2. Push the black flexible plastic housing onto the tip of the pole. Approximately 1.25" of the housing should be covering the pole tip as shown in Figure 3. The interference fit will be very tight.

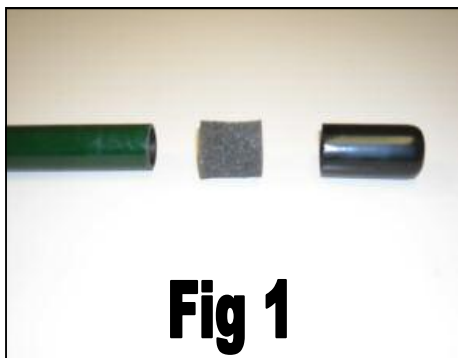

DB 36 and DB42 EST EXTENSION STRESS RELIEF SPLICE INSTALLATION

QTY 1: 2" x 12"
Stress relief splice
10-1630-21

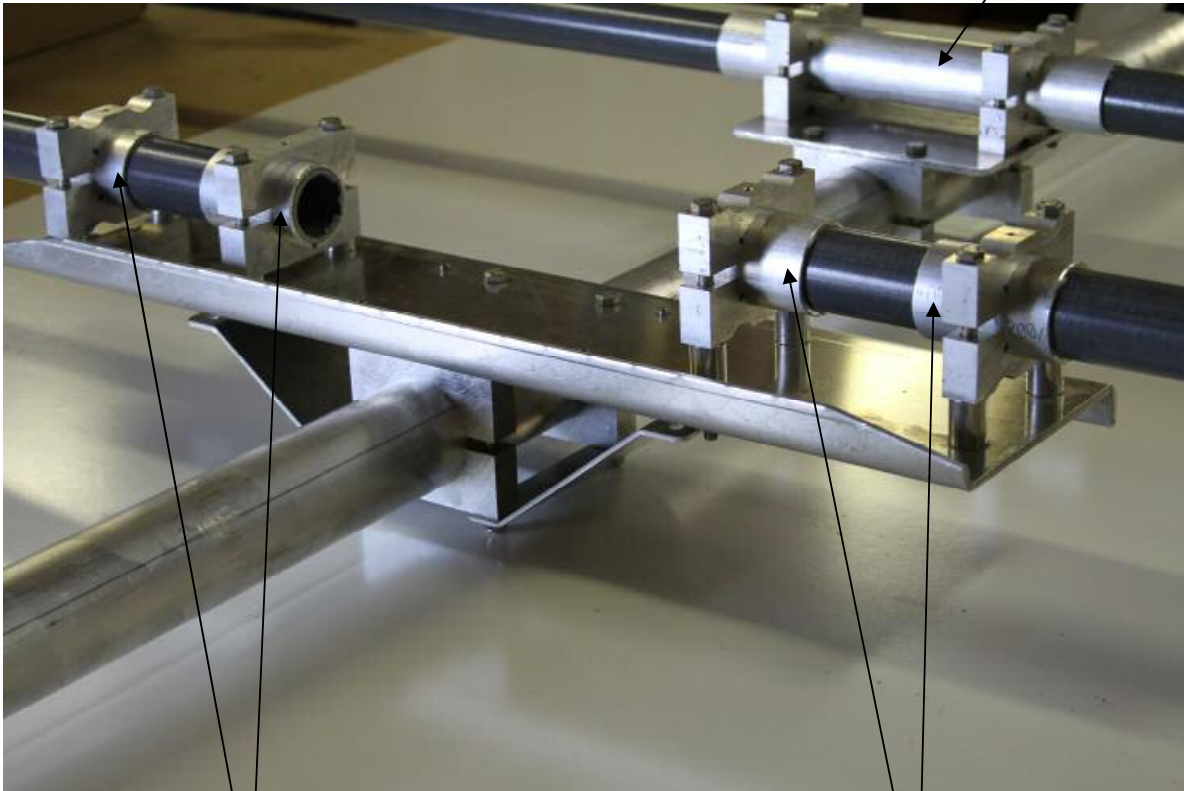

QTY 2: 2" x 3"
Stress relief splice
10-1630-11

QTY 2: 2" x 3"
Stress relief splice
10-1630-11

Note:

- Each stress relief splice is slotted and slides over the outside diameter of the 1.75" fiber-glass EST extension tubes
- PN 10-1630-01 2" x 3" Stress relief splice—Each splice should be centered to the middle of the aluminum saddle before tightening the aluminum saddles
- PN 10-1630-21 2" x 12" Stress relief splice—Mark the center of the splice and insert each Return extension (70-2028-011) to the mark, then tighten the aluminum saddles

Dream Beam 36 Boom Joint Assembly

Locate the following

- QTY 1: 10-1202-31 2.5" X 72" Aluminum boom section
- QTY 2: 10-1202-21 2.25 X 48" Aluminum boom section
- QTY 2: 10-1203-21 2.00 X 10" Aluminum joint piece

NOTE:

This procedure is to make the 2.5" to 2.25" joints of the boom twice the wall thickness. The 10" section will be held into place with the boom bolts that holds the entire joint together.

- Follow **Figure 1** for aligning 10-1203-21 inside 10-1202-21.
- Slide the two parts into 10-1202-31.
- Secure entire assembly with the bolts that are provided in kit number 72-0020-01.
- Repeat the same process for both sides of the 2.5" section of boom.
- The rest of the boom should be assembled following the manual on page 10.

Figure 1

Boom Joint Assembly Parts

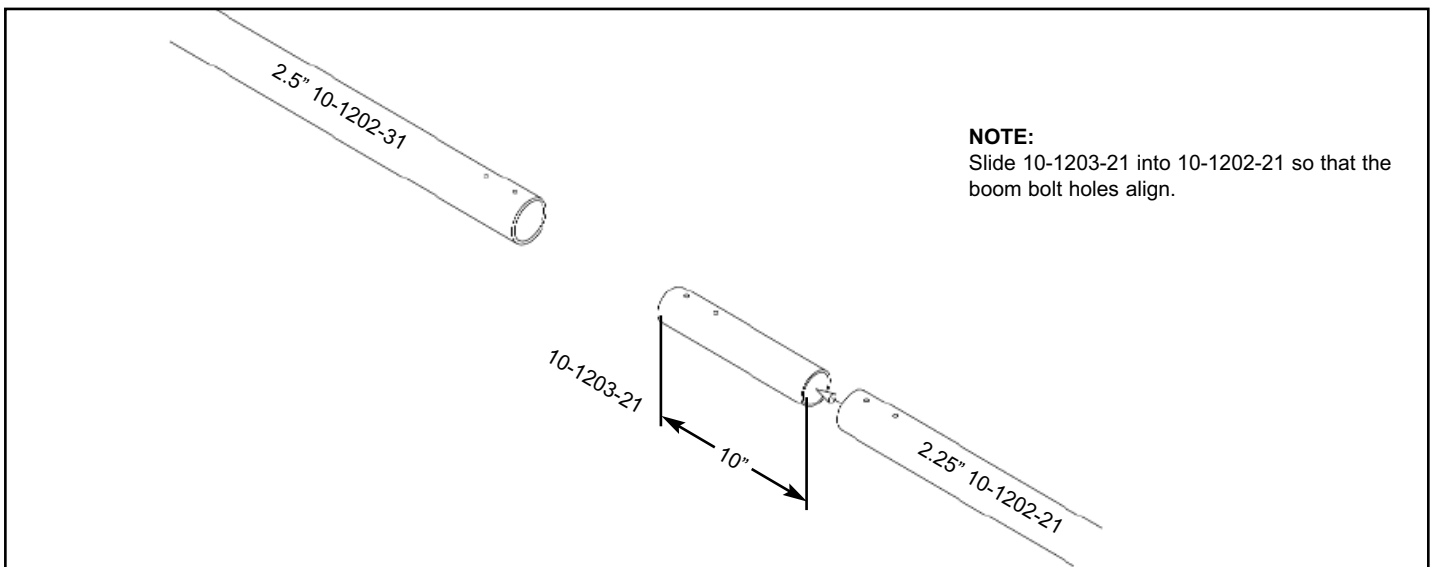
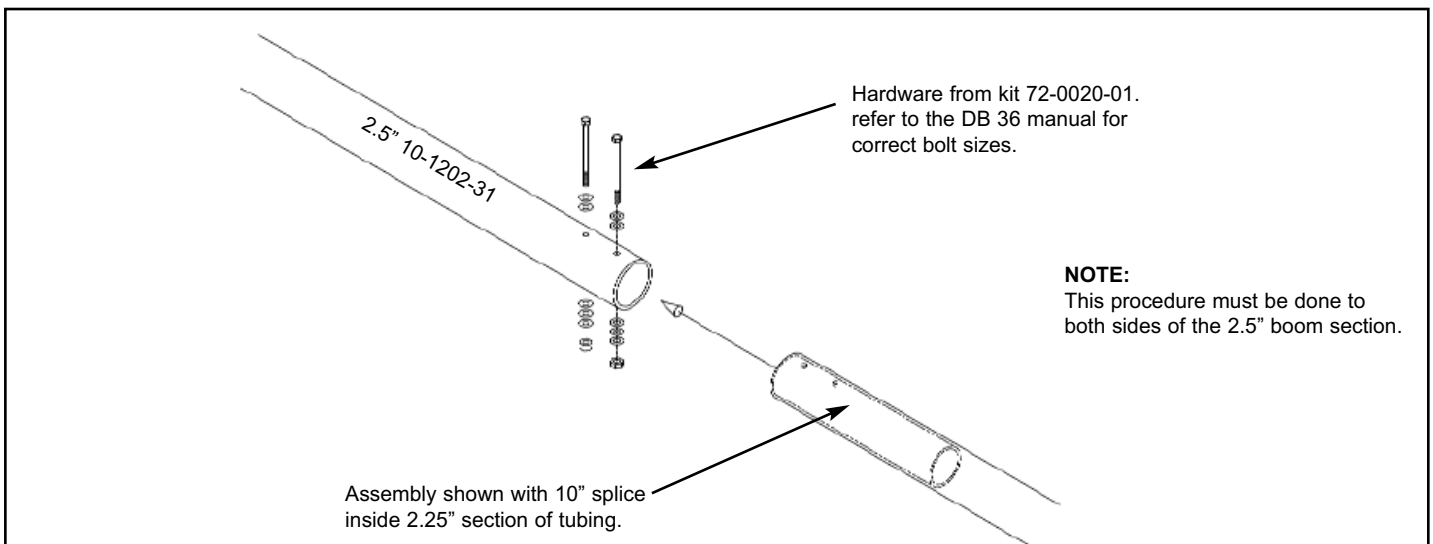

Figure 2

Boom Joint Assembly



Diverter Cone Installation - All loop antennas (except DB11)

NOTE:

Telescoping poles must be extended and completed before Diverter Cone and CPVC can be installed. When gluing, only apply glue to the outside of the CPVC tubing. This will prevent the glue from flowing into the CPVC tube and creating a blockage that will cause the antenna to fail.

- Follow **Figure 20** for gluing procedure of the Diverter Cone and CPVC. Let assembly dry for 10 minutes.
- Slide the Diverter Cone assembly into the fiberglass telescoping pole so that the 49" CPVC tubing slides into the fiberglass telescoping pole first. While sliding the assembly in, shaking or wiggling will help to allow for correct installation.
- Seat the Diverter Cone completing into the telescoping pole so that the 1/4" lip is the only part of the Diverter Cone visible in the telescoping pole as shown in **Figure 20A**
- Repeat the above steps for completing the other side of the element.

Figure 20

Diverter Cone and CPVC

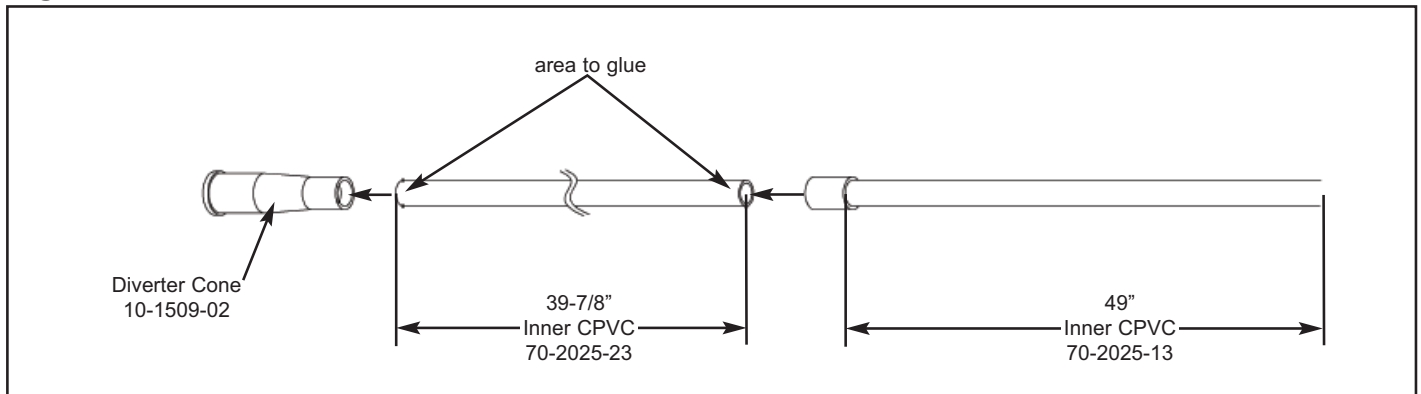
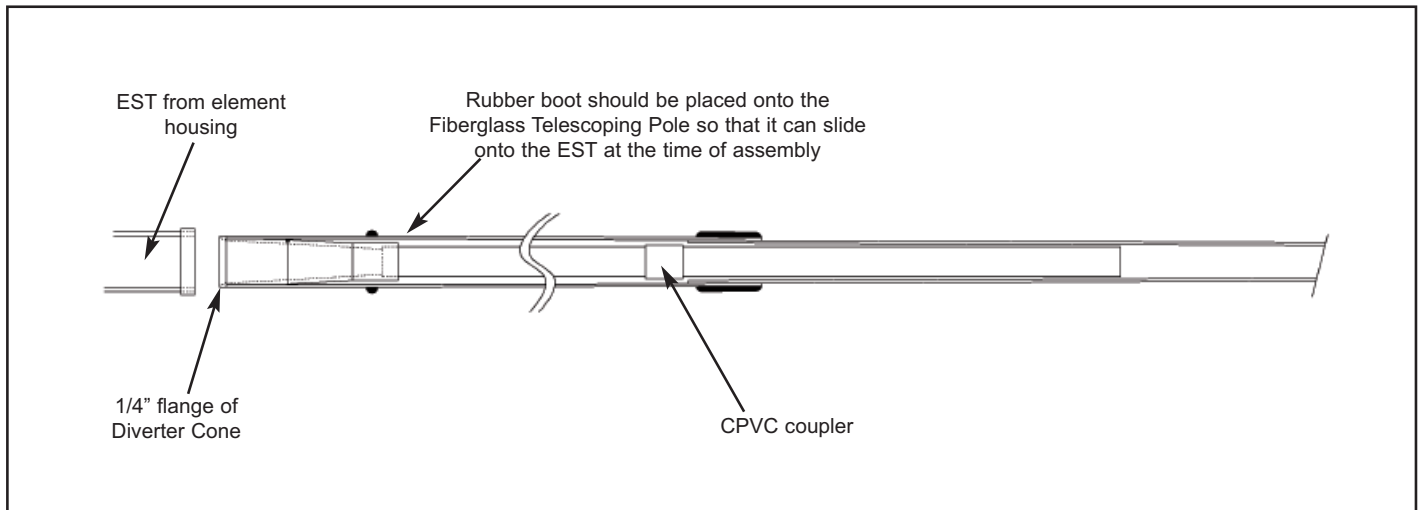

Figure 20A

EST Assembly



DB18 Center Boom Installation

Note: The DB18/18E boom center splice has had a slight change from the manual. Instead of a 1/4" bolt, the highlighted bolt below is now 5/16". For this bolt only, you will require three 5/16" washers at bottom of bolt. Note that the other 1/4" bolts for the boom all require 2 washers on top and 3 on the bottom.

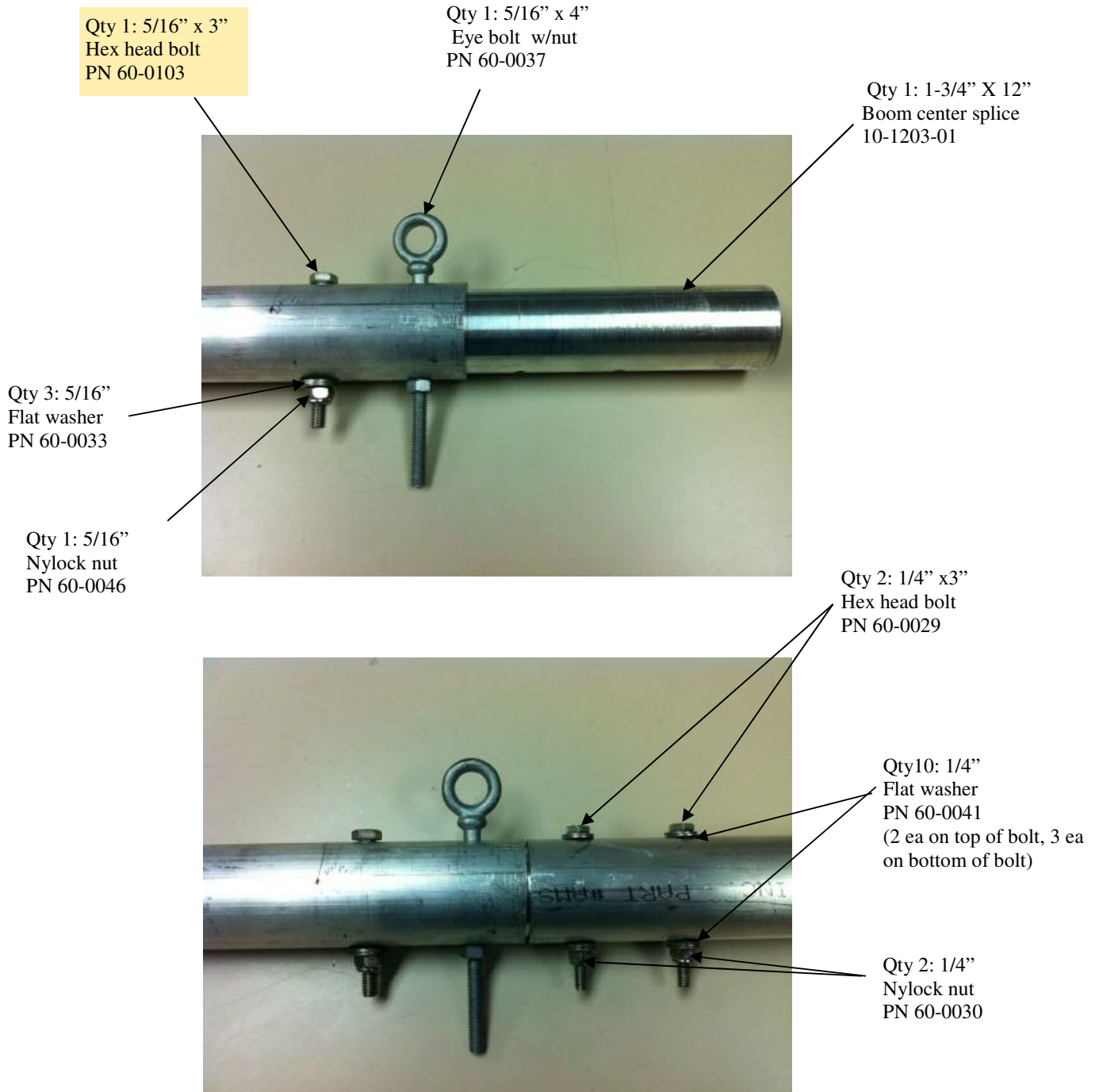



NOTICE TO ALL STEPPIR ANTENNA OWNERS:

There are certain features on the SteppIR electronic controllers that you have to enable in the internal software in order to “turn on” the feature.

If you have one of the following options, be sure to go into the software of your electronic controller and enable it. The feature will not work properly until you do so:

Verticals:

80m Coil (BigIR)
40/30 Coil (SmallIR)
80/40/30 Coil (SmallIR)

Yagi's:

6m Passive Element (2E, 3E, 4E, DB18, DB18E, DB36, DB42)
80m Dipole (DB36, DB42)

All Antennas:

Remote Driver Board

DB18E:

If you order the DB18E, you will need to go into the internal software and enable the “E” feature, or your antenna will effectively function as a DB18. This means you will not have a yagi on 40m and 30m until you enable the feature.

Stepp  **TM**